

Grizzly *Industrial, Inc.*®

MODEL T10009 5000 Kg DIGITAL CRANE SCALE OWNER'S MANUAL



COPYRIGHT © OCTOBER, 2007 BY GRIZZLY INDUSTRIAL, INC.
WARNING: NO PORTION OF THIS MANUAL MAY BE REPRODUCED IN ANY SHAPE
OR FORM WITHOUT THE WRITTEN APPROVAL OF GRIZZLY INDUSTRIAL, INC.

#JM10065 PRINTED IN CHINA

SECTION 1: SAFETY

WARNING!

This manual provides critical safety instructions on the proper setup, operation, maintenance and service of this machine/equipment.

Failure to read, understand and follow the instructions given in this manual may result in serious personal injury, including amputation, electrocution or death.

The owner of this machine/equipment is solely responsible for its safe use. This responsibility includes but is not limited to proper installation in a safe environment, personnel training and usage authorization, proper inspection and maintenance, manual availability and comprehension, application of safety devices, blade/cutter integrity, and the usage of personal protective equipment.

The manufacturer will not be held liable for injury or property damage from negligence, improper training, machine modifications or misuse.

WARNING!

For Your Own Safety Read Instruction Manual Before Operating This Equipment

The purpose of safety symbols is to attract your attention to possible hazardous conditions. This manual uses a series of symbols and signal words which are intended to convey the level of importance of the safety messages. The progression of symbols is described below. Remember that safety messages by themselves do not eliminate danger and are not a substitute for proper accident prevention measures.

DANGER

Indicates an imminently hazardous situation which, if not avoided, WILL result in death or serious injury.

WARNING

Indicates a potentially hazardous situation which, if not avoided, COULD result in death or serious injury.

CAUTION

Indicates a potentially hazardous situation which, if not avoided, MAY result in minor or moderate injury. It may also be used to alert against unsafe practices.

NOTICE

This symbol is used to alert the user to useful information about proper operation of the equipment.

WARNING

Safety Instructions for Crane Scales

1. **READ THROUGH THE ENTIRE MANUAL BEFORE USING.** This crane scale presents serious injury hazards to untrained users.
2. **NEVER ALLOW UNQUALIFIED PERSONNEL TO SERVICE THIS SCALE.** Servicing the scale incorrectly may reduce the maximum holding capacity of the load cell or cause the scale to give incorrect readings, which may result in overloading.
3. **DO NOT LIFT MORE THAN THE MAXIMUM SUGGESTED CAPACITY.** Be aware that the load weight, harnesses, and load bearing equipment all contribute to the total load weight. Overloading may cause the load to fall.
4. **NEVER LIFT HEAVY LOADS WHEN TIRED, OR UNDER THE INFLUENCE OF DRUGS OR ALCOHOL.** Be mentally alert at all times when lifting or moving heavy loads.
5. **ONLY ALLOW TRAINED AND PROPERLY SUPERVISED PERSONNEL TO OPERATE SCALE.** Make sure operation instructions are safe and clearly understood.
6. **NEVER LEAVE A LOAD WHILE SUSPENDED.** Lower the load to the ground and un-hook all loads and harnesses before leaving the crane scale unattended.
7. **NEVER SUSPEND THE LOAD OVER OR NEAR A PERSON.** Loads may fall at any given time due to overloading, improper loading procedures, or failure of a component.
8. **ALWAYS DISCONNECT FROM POWER SOURCE BEFORE SERVICING.** Make sure switch is in OFF position, charger is unplugged, and battery disconnected before servicing.
9. **CHECK FOR DAMAGED PARTS BEFORE USING SCALE.** Check for broken parts, loose bolts, cracked or worn components and any other conditions that may affect machine operation. Repair or replace damaged parts.
10. **USE RECOMMENDED ACCESSORIES.** Refer to the instruction manual for recommended accessories. The use of improper accessories may increase risk of injury.
11. **NEVER LET LOADS SWING.** Unsteady loads may become unbalanced and fall. Swinging motions cause wear on components and may cause them to break.
12. **USE CORRECT HARNESES.** Never use oversized or multiple harnesses.
13. **CHARGE ONLY USING THE SUPPLIED CHARGER AND BATTERY.** Do not use with other batteries, chargers or scales.
14. **DO NOT EXPOSE BATTERY OR CHARGER TO WET OR RAINY CONDITIONS.** Moisture greatly increases the risk of a shock hazard.
15. **DO NOT STORE BATTERY WITH CONDUCTIVE MATERIALS.** Storing the battery in a box of screws or nails can cause shorting across the battery poles.

SECTION 2: INTRODUCTION

Foreword

It is our pleasure to provide this manual with the Model T10009. It was written to encourage safety considerations and guide you through general operating procedures and maintenance.

The specifications, details, and photographs in this manual represent the Model T10009 as supplied when the manual was prepared. However, owing to Grizzly's policy of continuous improvement, changes may be made at any time with no obligation on the part of Grizzly.

Machine Data

Maximum Capacity..5,000 Kg (11,026 lbs.)
Minimum Load.....41 Kg (90 lbs.)
Accuracy Class.....OIML Class III
Crane Battery.....Rechargeable 6V/10Ah
Crane Battery Life.....+80 hrs.
Crane Adapter.....AC220V/DC9V1.5A
Operating Temperature.....-10°C – 40°C/
14°F – 104°F
Operating Humidity.....90% or Less
Remote Control Battery.....#5, 1.5Vx2 (AA)
Digital Display.....5 Digit LED
Character Display Height.....30mm
Scale Body.....Die-Cast Aluminum Case

Contact Info

If you have any comments regarding this manual, please contact us:

Grizzly Industrial, Inc.
C/O Technical Documentation Manager
P.O. Box 2069
Bellingham, WA 98227-2069
Email: manuals@grizzly.com

Most importantly, we stand behind our tools. If you have any service questions or parts requests, please call or write us at the location listed below.

Grizzly Industrial, Inc.
1203 Lycoming Mall Circle
Muncy, PA 17756
Phone: (570) 546-9663
Fax: (800) 438-5901
E-Mail: techsupport@grizzly.com
Web Site: <http://www.grizzly.com>

⚠ WARNING

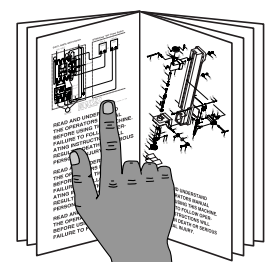

Read the manual before operation. Become familiar with this scale, its safety instructions, and its operation before beginning any work. Serious personal injury may result if safety or operational information is not understood or followed.

SECTION 3: SET UP

Unpacking

Your crane scale was carefully packaged for safe shipping. If you discover any damage after you have signed for delivery, *immediately call Customer Service at (570) 546-9663 for advice.*

Save the containers and all packing materials for possible inspection by the carrier or its agent. *Otherwise, filing a freight claim can be difficult.*

When you are completely satisfied with the condition of the shipment, you should inventory the contents.

Inventory

Model T10009 Inventory (Figure 1)

- A. Crane Scale 1
- B. Scale Battery Charger 1
- C. Remote Control..... 1

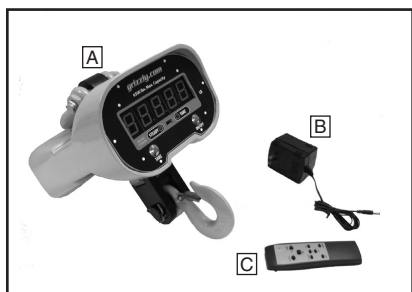

Figure 1. Model T10009 inventory

Site Consideration

Weight Capacity

The Model T10009 crane scale has a maximum capacity of 5,000 Kg (11,026 lbs.). When choosing a mounting site, verify that the lifting structure can withstand at least the maximum loading capacity as well as any possible overloading that may occur.

Working Clearances

Consider existing and anticipated needs, dimensions of your weighing platform, size of material to be weighed, and whether you need the scale to be mobile or in a stationary location when establishing an installation site for your crane scale. For an accurate reading, there must not be any items near the scale or weighing platform that may lean or fall and add weight.

Power Outlets

The Model T10009 crane scale includes a remote control and scale battery charger. When establishing a site for your scale, make sure outlets are located near the scale so power or extension cords are clear of high-traffic areas.

Do not place the crane scale in areas of high electrical fields. Electrical fields can effect scale accuracy.

⚠ CAUTION

No list of safety guidelines is complete, because every work environment is different. Always consider safety first and use common sense. Failure to use this tool with caution and respect could result in serious personal injury.

Mounting and Loading Hardware

When attaching hardware to the crane scale:

- DO NOT attach multiple chains or harnesses directly to the scale. Only one point of contact should be used on the hook and shackle to lessen the chance of the load falling and to allow proper load alignment.
- DO NOT attach oversized items or harnesses directly to the scale. Oversized loading hardware create multiple points of contact and will not fit properly with the crane scale hardware. Inaccurate readings, uneven, and dangerous loads may result.

Refer to **Figures 2 & 3** for the dimensions of Model T10009.

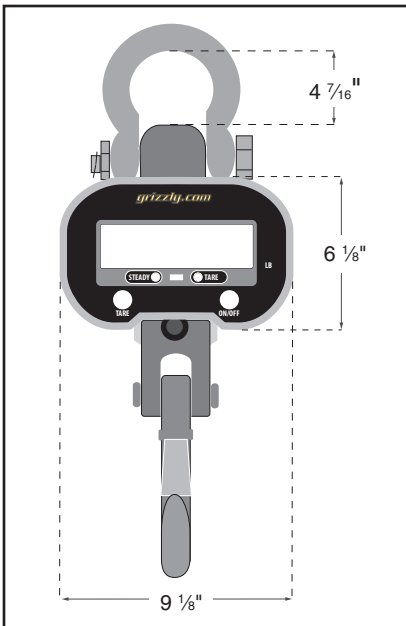

Figure 2. Scale front view measurements.

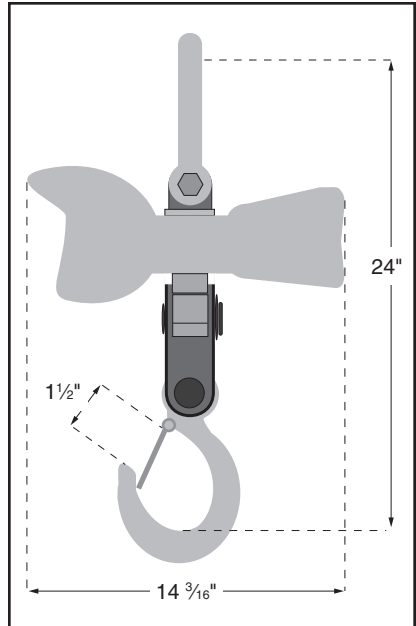

Figure 3. Scale side view measurements.

⚠️ WARNING

Like all tools there is potential danger when operating this tool. Accidents can be caused by lack of familiarity or failure to pay attention. If normal safety precautions are overlooked or ignored, serious personal injury may occur.

NOTICE

To maintain accuracy, the scale should remain hanging and not be allowed to rest on the ground for a significant amount of time.

SECTION 4: OPERATIONS

Scale Functions

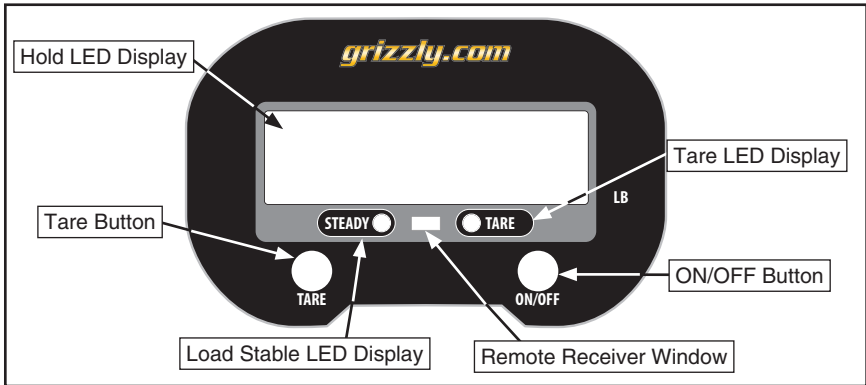

Figure 4. Scale face.

Turning the Scale ON

After your crane scale has been properly suspended, familiarize yourself with the functions both on the scale and on the remote control. Begin by holding down the ON/OFF button on the scale to turn it **ON** (Figure 4). Each time the scale is turned on, it will flash a series of displays. Use the table below to familiarize yourself with the display and its meanings.

Function	Display	Action
Off/On	5000	Maximum capacity in Kg.
	U X.XX	Current battery voltage
	99999	Warming up
	88888	
	77777	
	66666	
	55555	
	44444	
	33333	
	22222	
	11111	
	00000	
	- XX	Current weight
	0	Steady light will engage, ready

To guarantee accuracy for your crane scale, allow it warm up without a load for 3-5 minutes.

Tare Function

The tare function will allow you to automatically deduct the weight of the weighing platforms or containers, resulting in a final weight of only the items that you want weighed (the net weight). When your scale is ready, attach your weighing platform to the lifting hook at the bottom of the scale, then wait until the "STEADY" light comes on. Before placing any items on the platform, deduct the weight of the platform by pressing the TARE button on the scale (Figure 4), or by pressing Tare on the remote control. After you have selected the Tare function for the platform, the scale will return to 0 lbs. between loads until you turn off the scale.

Power Saving

If the load is left at stable status, ("STEADY" as shown in Figure 4), for longer than 15 minutes, the screen will flash "-" to save power and will return to normal weighing readings when the load is changed. If the load is left at stable status for over 60 minutes, the scale will turn **OFF** automatically.

Overload Warning

If the load exceeds the maximum capacity (net + tare weight), **OVER** will be displayed on the screen. **DO NOT** overload the scale. Overloading the scale may result in injury, damage the scale, and void your warranty.

Turning the Scale OFF

To turn the scale **OFF**, hold down the ON/OFF button on the scale or hold down the OFF button on the remote control.

Note: The scale will not turn **OFF** unless it is at the main weighing screen.

NOTICE

Do not use this scale during lightning and rain storms or other inclement weather. Turn the scale **OFF**, unplug any charging equipment, and remove the battery.

NOTICE

If this scale is used for the selling of goods, it must be "Legal for Trade" and calibrated regularly.

Remote Control Functions

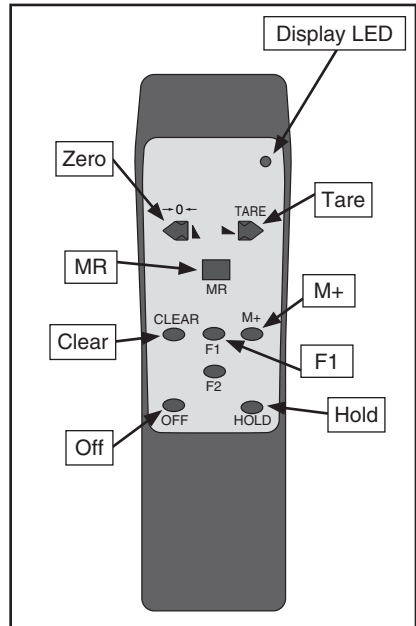

Figure 5. Remote control buttons.

Note: The remote control is a generic remote and may contain buttons that will not be used with this particular model. Should you lose the included remote control, these functions cannot be completed. To obtain a replacement controller from Grizzly, call 1-800-523-4777.

Zero Function

Generally, your scale will initially read the weight of the hook. To return your scale to zero lbs., press the →0← button on the remote control.

Scale Battery

The scale will automatically display the current scale battery voltage when you turn the scale **ON** and **OFF**. To check the voltage during use, press the MR button on the remote control and the screen will display SHIFT. Press the F1 button and the screen will display U X.XX. To return to the main display, press MR again.

When the battery voltage is lower than U 5.80, the screen will flash to alert you. The scale will continue to display for approximately one minute longer and then turn **OFF** automatically. The scale will need to be charged before further use.

The Model T10009 has an easy to remove battery for convenient charging. Remove the two outer cap screws from the back of the scale body. Slide the battery out and unplug the wire clip connection, as shown in **Figure 6**.



Figure 6. Unplugging the battery.

To recharge the battery:

1. Turn the scale **OFF**.
2. Connect the supplied adapter into the socket located in the back of the scale, then into a grounded 110V outlet. The light turns orange while charging and turns red when charging is complete.

Note: *The battery should re-charge for at least 8 hours.*

Hold Function

When the load has been added to the scale, wait until the STEADY light goes off, signifying that the load is stable (**Figure 4**). If you would like the weight value to remain on the screen, press the HOLD button on the remote control and the Hold LED will flash on the display (**Figure 4**). To clear the screen, press the HOLD button again.

Advance Tare Weight

To input a known tare weight before weighing an item, press MR and the screen will display SHIFT. Press TARE, and the screen will display 00000. To input the desired weight, scroll to the right by pressing the right arrow (TARE) button on the remote control until you come to the number that you would like to change. To increase the number from zero, press the left button (→ 0 ←) on the remote control. To submit the tare amount, press MR and the TARE light will come on the scale, automatically deducting the imputed tare weight. The tare weight will stay the same until the scale is turned **OFF**.

Clear Function

To clear, press the CLEAR button and the screen will flash CLR. If you would like to approve the clear command, press the MR button and the screen will display "End", and return to the main screen. If you would like to cancel the clear command, press the CLEAR button again and the display will return to the main screen.

Reference Guide

For quick references and questions about scale displays, use the charts below for assistance.

Function	Button	Display	Action
On	ON/OFF	5000	Maximum capacity in Kg.
		U X.XX	Current battery voltage
		99999	Warming up
		88888	
		77777	
		66666	
		55555	
		44444	
		33333	
		22222	
		11111	
		00000	
		- XX	Current weight
		0	Steady light will engage, ready

OFF	OFF or ON/OFF	U X.XX	
		OFF	Scale is OFF

Zero	→ 0 ←	0	Display reads 0
------	-------	---	-----------------

Tare	TARE/ TARE	0.00	Display reads 0, Tare LED is on
------	------------	------	---------------------------------

Hold	HOLD	XXXXX	Weight is held, press HOLD to exit
------	------	-------	------------------------------------

Function	Button	Display	Button	Action
Voltage	MR	SHIFT	F1	U X.XX, press MR to exit
Advance Tare	MR	SHIFT	TARE/TARE	TARE to scroll right
				to increase number
				M+ to submit and scroll left
				MR to submit total, "TARE" LED is on
Clear	CLEAR	CLR	MR	End, Confirm & return to main screen
			CLEAR	Cancel & return to main screen

SECTION 5: MAINTENANCE

General

Regularly check mounting hardware for cracks, unsafe wear, deformation, or warping. DO NOT attempt to fix the mounting hardware! Discard and replace all damaged mounting hardware. Regularly check for loose pins, rings, screws, and safety latches. Tighten or replace any loose items. Damaged or loose parts may cause the load to fall and may result in serious injury.

Always keep the scale in a hanging position to relieve strain on the load cell. Never leave a load or weighing equipment on the scale when not in use. This may cause excessive strain on the precision weighing device and may result in inaccurate readings and shorten the life of your scale.

When recharging the scale battery, charge for at least 8 hours. Excessive charging will not damage the battery. Batteries must be recycled or disposed of properly.

If your scale malfunctions beyond the scope of this manual, do not attempt to fix it yourself. Contact a certified professional for any electrical or detailed calibration work.

If the scale becomes dirty, clean the screen with a soft cloth using a mild window cleaner or detergent. Avoid using paper towels. DO NOT use solvents, chemicals or other corrosive materials to clean the scale.

If the scale will not be used for a prolonged amount of time, remove the battery. Suspend the scale at all times and do not allow it to rest on the ground.

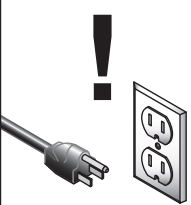
	
⚠ WARNING Always DISCONNECT POWER before servicing, adjusting, or doing maintenance to reduce the risk of accidental injury or electrocution.	

	BATTERY MUST BE RECYCLED OR DISPOSED OF PROPERLY. Consult your local disposal company for recycling options in your area.
---	--

SECTION 6: SERVICE

Troubleshooting

Symptom	Possible Cause	Solution
No display when the scale is turned ON .	<ol style="list-style-type: none">1. Battery is dead or damaged.2. Battery contact is loose.	<ol style="list-style-type: none">1. Check and charge or replace battery.2. Tighten the battery contact.
Display flashes.	<ol style="list-style-type: none">1. Low battery.	<ol style="list-style-type: none">1. Recharge or replace battery.
Scale will not turn ON or OFF .	<ol style="list-style-type: none">1. ON/OFF button is damaged.2. Scale is still in function mode.	<ol style="list-style-type: none">1. Check and clean the button and button contact.2. Exit out of the function to the main screen, then turn the scale OFF.
Display will not show a stable weight.	<ol style="list-style-type: none">1. The load is unstable.2. Load cell cable is damaged.3. The scale has been in a damp environment for a prolonged amount of time.	<ol style="list-style-type: none">1. Stabilize the load.2. Check and replace load cell.3. Put the scale in a dry environment.
Recharge indicator light will not turn ON .	<ol style="list-style-type: none">1. Damaged adaptor.2. The adaptor is not fully plugged into the scale or outlet.	<ol style="list-style-type: none">1. Check or replace the adaptor.2. Insert the plug again.
Scale unable to tare.	<ol style="list-style-type: none">1. Damaged TARE button.	<ol style="list-style-type: none">1. Check and clean the button and button contact.
Large weight error.	<ol style="list-style-type: none">1. Scale is not suspended properly.	<ol style="list-style-type: none">1. Check the scale, harnesses, etc. Review Setup section on Page 4.
Battery unable to charge.	<ol style="list-style-type: none">1. Battery is damaged.2. Outlet is damaged.3. Charger is damaged.	<ol style="list-style-type: none">1. Replace the battery.2. Replace the outlet.3. Replace the charger.
Remote will not work.	<ol style="list-style-type: none">1. Remote control is too far away from the scale.2. Dirty receiver window.3. Remote control batteries are low.4. Remote is broken.	<ol style="list-style-type: none">1. Move the remote closer to the scale.2. Check and clean window.3. Replace controller batteries.4. Replace remote.
The display will not show "0" with an empty load.	<ol style="list-style-type: none">1. The scale has not had enough time to warm up.2. The scale has been placed on the ground and not suspended for a prolonged time.	<ol style="list-style-type: none">1. Allow the scale to warm up for 3-5 minutes after turning it on.2. Suspend the scale.

T10009 Front View Parts Breakdown

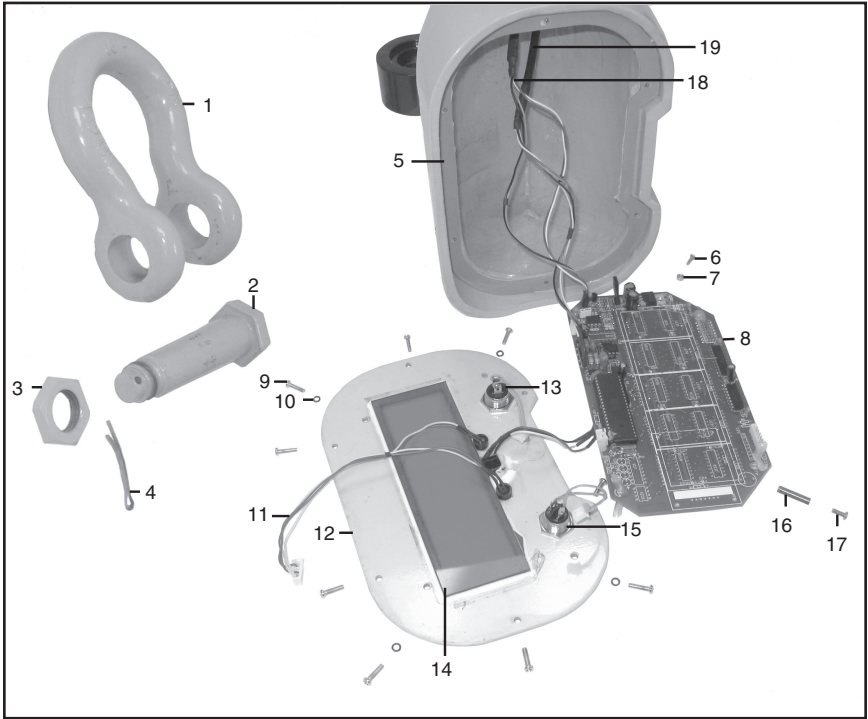

REF PART #	DESCRIPTION
1	PT10009001 ANCHOR SHACKLE
2	PT10009002 SPECIAL BOLT 1-3/8 -6
3	PN38 HEX NUT 1-3/8 -6
4	PT10009004 COTTER PIN
5	PT10008005 FRONT GASKET
6	PS79M PHLP HD SCR M3-.5 X 8
7	PN07M HEX NUT M3-.5
8	PT10009008 CIRCUIT BOARD
9	PS55M PHLP HD SCR M3-.5 X 10
10	PLW09M LOCK WASHER 3MM

REF PART #	DESCRIPTION
11	PT10009011 LED W/ WIRE ASSEMBLY
12	PT10009012 SCALE FACE PLATE
13	PT10008014 TARE WIRE ASSEMBLY
14	PT10008015 SCREEN
15	PT10008016 POWER WIRE ASSEMBLY
16	PT10008017 COUPLING HEX NUT M3-.5 X 20
17	PS79M PHLP HD SCR M3-.5 X 8
18	PT10009018 FRONT BATTERY WIRE ASSY
19	PT10009019 LOAD CELL WIRE ASSY

T10009 Rear View Parts Breakdown

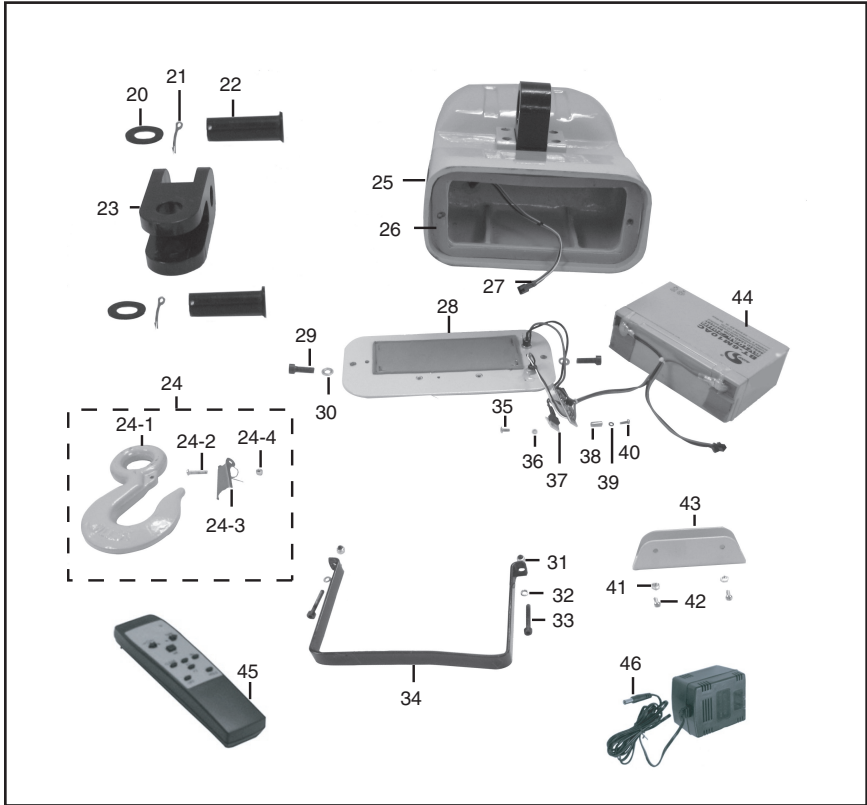

REF PART # DESCRIPTION

20	PT10009020	FLAT WASHER 29MM
21	PT10009021	COTTER PIN
22	PT10009022	CLEVIS PIN 29 X 85
23	PT10009023	LIFTING YOKE
24	PT10009024	HOOK ASSEMBLY
24-1	PT10008028-1	HOOK
24-2	PS52M	PHLP HD SCR M4-.7 X 20
24-3	PT10008028-3	SAFETY LATCH
24-4	PLN01M	LOCK NUT M4-.7
25	PT10009025	SCALE BODY
26	PT10008030	REAR GASKET
27	PT10009027	REAR BATTERY WIRE ASSY
28	PT10008032	REAR PLATE
29	PSB02M	CAP SCREW M6-1 X 20
30	PW03M	FLAT WASHER 6MM
31	PLN01M	LOCK NUT M4-.7

REF PART # DESCRIPTION

32	PLW02M	LOCK WASHER 4MM
33	PSB162M	CAP SCREW M4-.7 X 25
34	PT10008038	BATTERY BRACKET
35	PS79M	PHLP HD SCR M3-.5 X 8
36	PT10008040	SPACER
37	PT10008041	BATTERY CIRCUIT W/WIRE ASSY
38	PT10008042	COUPLING HEX NUT M3-.5 X 11
39	PLW09M	LOCK WASHER 3MM
40	PS79M	PHLP HD SCR M3-.5 X 8
41	PN04M	HEX NUT M4-.7
42	PS38M	PHLP HD SCR M4-.7 X 10
43	PT10008045	BATTERY BOX HANDLE
44	PT10008048	BATTERY 6V
45	PT10006014	REMOTE CONTROL
46	PT10006032	BATTERY CHARGER

WARRANTY

Grizzly Industrial, Inc. warrants every product it sells for a period of **1 year** to the original purchaser from the date of purchase. This warranty does not apply to defects due directly or indirectly to misuse, abuse, negligence, accidents, repairs or alterations or lack of maintenance. This is Grizzly's sole written warranty and any and all warranties that may be implied by law, including any merchantability or fitness, for any particular purpose, are hereby limited to the duration of this written warranty. We do not warrant or represent that the merchandise complies with the provisions of any law or acts unless the manufacturer so warrants. In no event shall Grizzly's liability under this warranty exceed the purchase price paid for the product and any legal actions brought against Grizzly shall be tried in the State of Washington, County of Whatcom.

We shall in no event be liable for death, injuries to persons or property or for incidental, contingent, special, or consequential damages arising from the use of our products.

To take advantage of this warranty, contact us by mail or phone and give us all the details. We will then issue you a "Return Authorization Number," which must be clearly posted on the outside as well as the inside of the carton. We will not accept any item back without this number. Proof of purchase must accompany the merchandise.

The manufacturers reserve the right to change specifications at any time because they constantly strive to achieve better quality equipment. We make every effort to ensure that our products meet high quality and durability standards and we hope you never need to use this warranty.

Please feel free to write or call us if you have any questions about the machine or the manual.

Grizzly Industrial, Inc.
1203 Lycoming Mall Circle
Muncy, PA 17756
Phone: (570) 546-9663
Fax: (800) 438-5901

E-Mail:
techsupport@grizzly.com

Web Site: <http://www.grizzly.com>

Thank you again for your business and continued support. We hope to serve you again soon!

